

S DISPENSERS SELF SERVICE K44

IT. Completa gamma di distributori per carburanti ad uso privato. Robusta struttura dotata di sportello anteriore per rendere facile la manutenzione. Pompa a palette di elevata portata. Bypass incorporato.

Pistola automatica con raccordo girevole. Filtro di assorbimento acqua incorporato (o a richiesta secondo i modelli) in grado di garantire un prodotto erogato libero da impurità.

Dotati di contaltri volumetrico a disco oscillante con indicazione meccanica.

FR. Gamme complète de distributeurs pour carburants à usage privé. Structure robuste pourvue de porte avant pour faciliter l'entretien. Pompe à ailettes au débit élevé. By-pass incorporé.

Pistolet automatique avec raccord pivotant. Filtre à absorption d'eau incorporé (ou sur demande selon les modèles) en mesure de garantir la distribution d'un produit exempt d'impuretés.

Pourvus de compteurs volumétriques à disque oscillant avec indication mécanique.

DE. Komplette Palette von Kraftstoff-Zapfsäulen für Privatgebrauch. Widerstandsfähige Struktur mit Fronttür zur leichteren Wartung. Flügelzellenpumpe mit hoher Förderleistung. Integriertes ByPass Ventil.

Automatische Zapfpistole mit Schlauchdrehgelenk. Eingebauter (oder je nach Modell auf Wunsch erhältlicher) Wasseraufnahmefilter, damit das Produkt ohne Verunreinigungen abgegeben wird.

Ausgestattet mit volumetrischem Taumelscheiben-Literzähler mit mechanischer Anzeige.

PERFORMANCE

- Portata fino a 90 l/min
- Precisione del conteggio: +/- 1 %
- Funzionamento continuo AC
- Rumorosità minore di 75 dB
- Protezione IP55

- Débit : jusqu'à 90 l/min
- Précision : +/- 1 %
- Fonctionnement continu CA
- Bruit : inférieur à 75 dB
- Protection : IP55

- Durchflussmenge bis 90 l/Min.
- Abgabegenauigkeit: +/- 1 %
- Dauerbetrieb AC
- Kleinster Lärmpegel 75 dB
- Schutzklasse IP55

DIMENSIONS

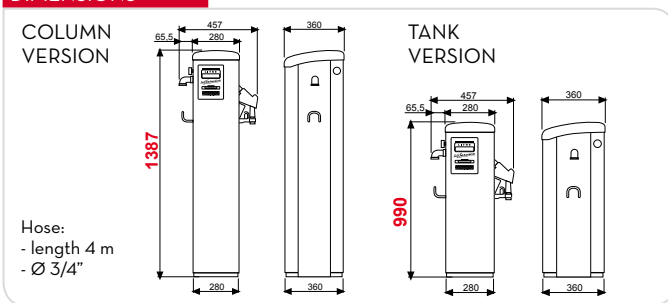

PRODUCTS' RANGE WEIGHT AND PACKAGING

Code	Weight		Packaging		N. Boxes/ Europallet	
	kg	lbs	mm	pcs/ box	✕	🚚
Column versions						
F0073701B	67	148	1478x488x400	1	6*	4
F0074001B	75	165	1478x488x400	1	6*	4
F0074002A	75	165	1478x488x400	1	6*	4
Tank versions						
F00737B0B	57	126	1080x488x400	1	6*	4
F00740B0B	65	143	1080x488x400	1	6*	4
F00737B2B	57	126	1080x488x400	1	6*	4

* Pallet XL



DISPENSERS

ANTIFREEZE

BIODIESEL

DIESEL

FOOD

GASOLINE

GREASE

KEROSENE

OIL

AdBlue®

WATER

WINDSCREEN

Flow-rate

up to
90 l/min
(up to 24 gpm)

Accuracy

+/-
1%

PIUSI[®]

DISPENSERS

PUMPS

METERS

NOZZLE METERS

NOZZLE

SPECIAL EQUIPMENTS

FLUID MONITORING

HOSE REEL

FILTERING

ACCESSORIES



Column version



Tank version



FEATURES



Mechanical meter integrated



Filter integrated (column version)

PRODUCTS' RANGE TECHNICAL DATA

Code	Description	Fluids type	Flow-rate		Voltage			Pump mod.	Meter mod.	Nozzle type	Filter		Inlet BSP	PC connection
			l/min	gpm	AC V./Hz	DC Volt	Power Watt				Amp. max.	H ₂ O filter		
Column versions														
F0073701B	Self service 70 K44	D	70	18	230/50	550	3,3	Panth 72	K44	Aut.	YES	30 µ	1"1/2	NO
F0074001B	Self service 100 K44	D	90	24	230/50	1150	5,7	E 120	K44	Aut.	YES	30 µ	1"1/2	NO
F0074002A	Self service 100 K44 Pulser	D	90	24	230/50	1150	5,7	E 120	K44P	Aut.	YES	30 µ	1"1/2	NO
Tank versions														
F00737B0B	Self service 70 K44 Tank	D	70	18	230/50	550	3,3	Panth 72	K44	Aut.	NO	-	1"1/2	NO
F00740B0B	Self service 100 K44 Tank	D	90	24	230/50	1150	5,7	E 120	K44	Aut.	NO	-	1"1/2	NO
F00737B2B	Self service 70 K44 Tank Pulser	D	70	18	230/50	550	3,3	Panth 72	K44P	Aut.	NO	-	1"1/2	NO

Upon request it is available with different voltages and 60 Hz frequency